







Features

- Stainless steel inner band to reduce friction.
- Roller Guide, Ball Bearing Guide are available.
- Adjustable end cushion.
- Smooth performance for slow speed.
- Free choice of stroke length up to 6000mm.

Specifications

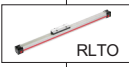
Type	RLTO	RLTF	RLO	RLF
Bore	Φ 16、25、32、40、50、63			
Power fluid	Filtered air with or without lubrication			
The range of pressure	7 bar			
The range of temperature	-10°C ~ +80°C (Don't freeze)			

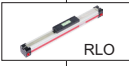
How to order

RLTO	-	G	-	25	-	1000	-	X	S	0	-	Y	1
Type		Roller Guide		Bore		Stroke		Seal	Grease Lubrication	Cushion		Sensor switch	Quantity
 RLTO				16 : Φ16 25 : Φ25 32 : Φ32 40 : Φ40 50 : Φ50 63 : Φ63		On quest * Up to 6000mm		X : NBR V : Viton	S : Standard L : Slow	0 : Standard 1 : Long		Y : AZRKH K : AZRK	1 : 1pc 2 : 2pcs
 RLTF													
 RLO													
 RLF													

※RLF suited for φ 25 ~ 32!

Weight table

Bore	Unit : kg					
	Φ 16	Φ 25	Φ 32	Φ 40	Φ 50	Φ 63
at 0 mm stroke	0.22	0.65	1.44	1.95	3.53	6.41
per 100 mm stroke	0.1	0.197	0.354	0.415	0.566	0.925

Material

Part name	Material
Cylinder tube	Anodized aluminium
Carrier (piston)	Anodized aluminium
End caps	Aluminium, lacquered / Plastic (P10)
Sealing bands	Stainless steel
Seals	NBR (Option : Viton)
Screws	Galvanized steel
Dust covers, wipers	Plastic

Loads, Forces and Moments

Choice of cylinder is decided by :

- Permissible loads, forces and moments
- Performance of the pneumatic end cushions

- The main factors here are the mass to be cushioned and the piston speed at start of cushioning (unless external cushioning is used, e. g. hydraulic shock absorbers).
- The adjacent table shows the maximum values for light, shock-free operation, which must not be exceeded even in dynamic operation.
- Load and moment data are based on speeds $V \leq 0.5$ m/s.

When working out the action force required, it is essential to take into account the friction forces generated by the specific application or load.

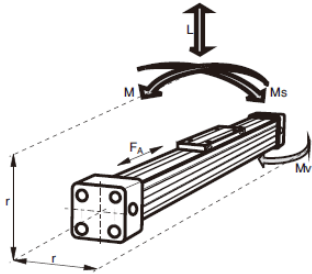

$$M = F \cdot r$$

Bending moments are calculated from the centre of the linear actuator

Bore		Φ 16	Φ 25	Φ 32	Φ 40	Φ 50	Φ 63
Theoretical Action Force at 6 bar[N]		120	295	483	754	1178	1870
effective Action Force F_A at 6 bar[N]		78	250	420	640	1000	1550
max. Moments	M [Nm]	4	15	30	60	115	200
	M_s [Nm]	0.45	1.5	3	6	10	12
	M_v [Nm]	0.5	3	5	8	15	24
max. Load L[N]		120	300	450	750	1200	1650
Cushion Length [mm]		17	30	35	45		

Cushion Diagram

Work out your expected moving mass and read off the maximum permissible speed at start of cushioning.

Alternatively, take your desired speed and expected mass and find the cylinder size required.

Please note that piston speed at start of cushioning is typically ca. 50% higher than the average speed, and that it is this higher speed which determines the choice of cylinder. If these maximum permissible values are exceeded, additional shock absorbers must be used.

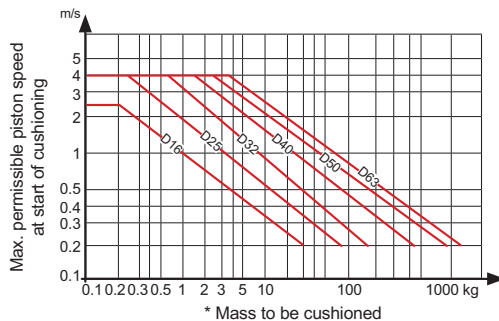

For cylinders with linear guides or brakes, please be sure to take the mass of the carriage or the brake housing into account.

Mid-Section Supports

To avoid excessive bending and oscillation of the cylinder, mid-section supports are required dependent on specified stroke lengths and applied loads. The diagrams show the maximum possible support spacings depending on the load.

Bending up to max. 0.5 mm is permissible between supports.

The midsection supports are clamped on to the dovetail profile of the cylinder tube.

They are also able to take the axial forces.

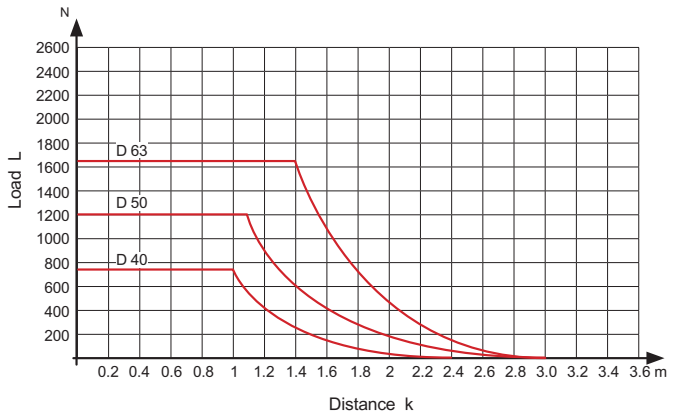
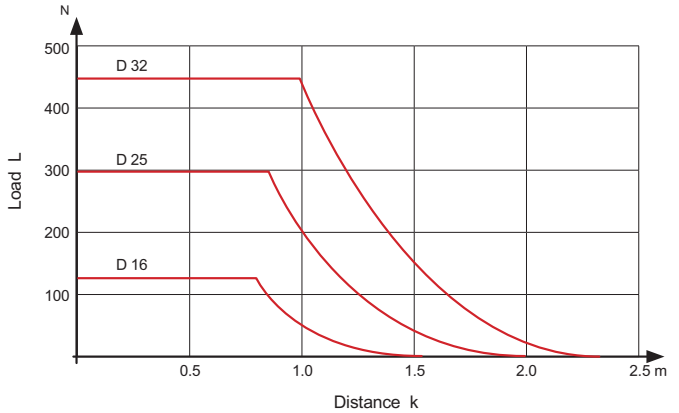
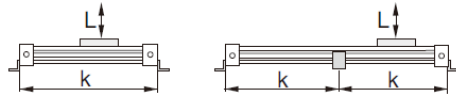

Control examples

Circuit diagram for end of stroke application. Intermediate positioning is also possible.

The cylinder is controlled by two 3/2 way valves (normally open). The speed can be adjusted independently for both directions.

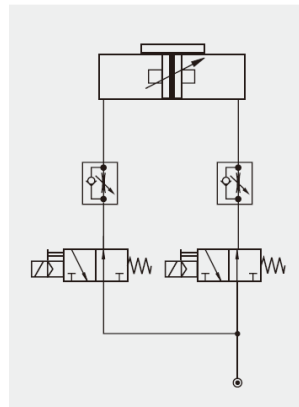

RLTO Standard type / Dimensional features

* Free choice of stroke length up to 6000mm.

● $\phi 25$

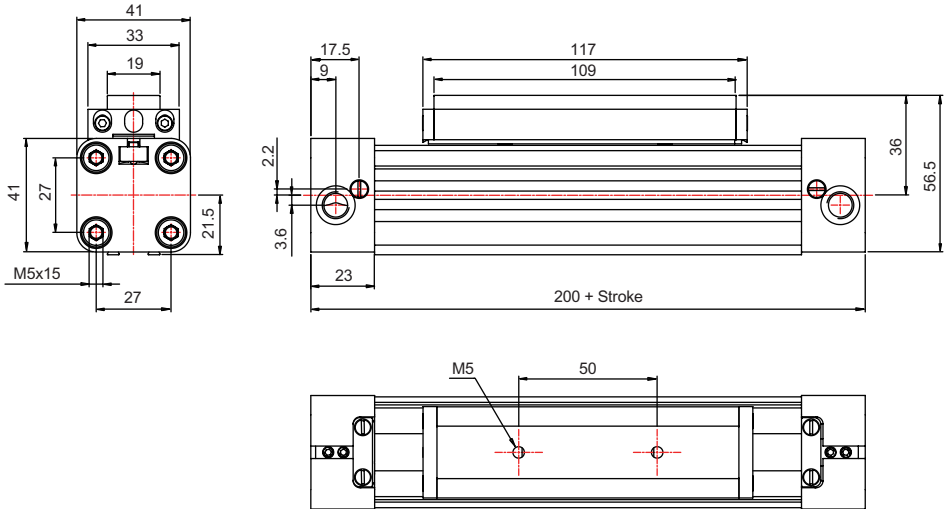

● Stroke

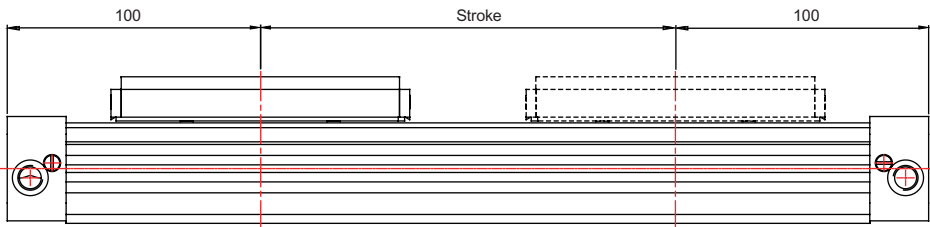

RLTF Standard type / Dimensional features

* Free choice of stroke length up to 6000mm.

● $\phi 25$

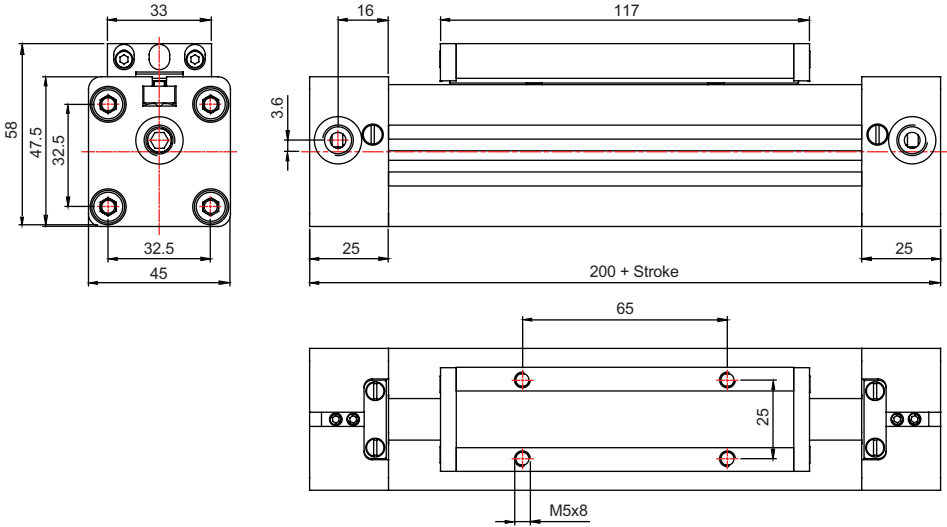

● Stroke

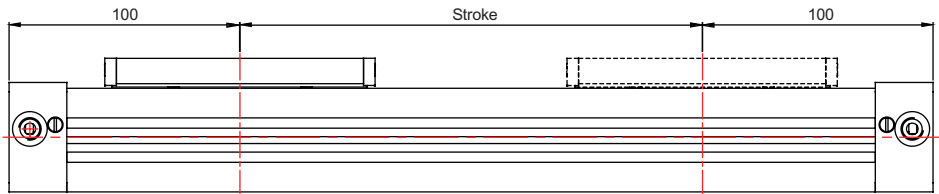

RLO Standard type / Dimensional features

* Free choice of stroke length up to 6000mm.

● $\phi 16$

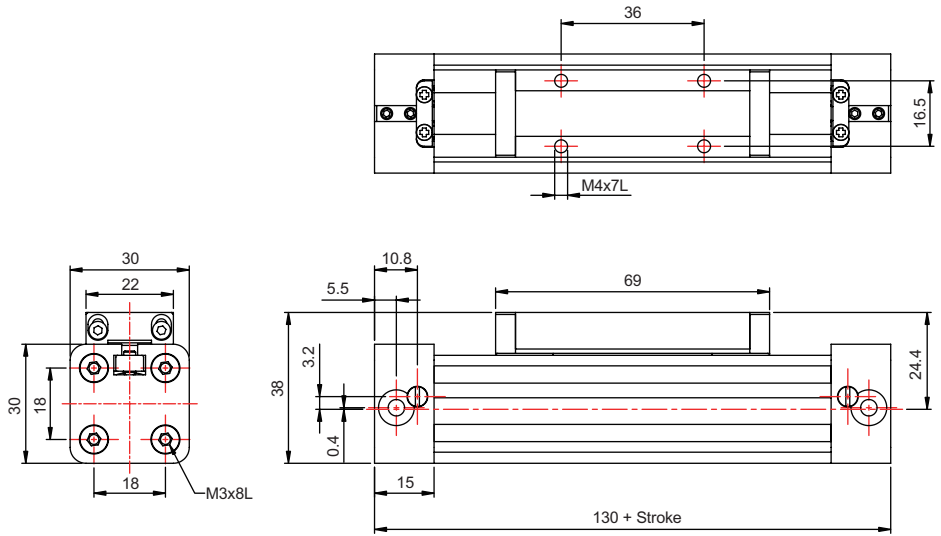

● Stroke

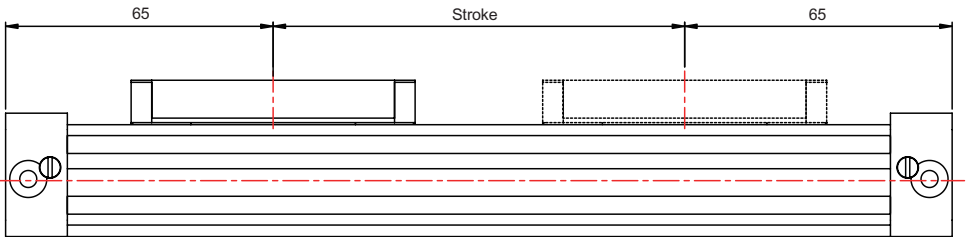

RLO-G Standard type with linear guide/ Dimensional features

* Free choice of stroke length up to 6000mm.

● $\phi 16$

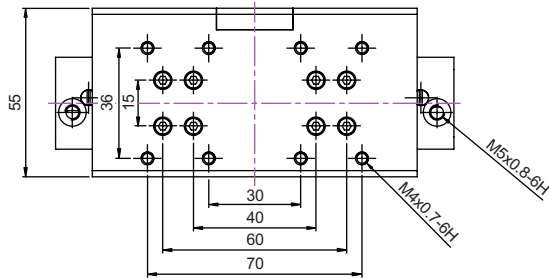
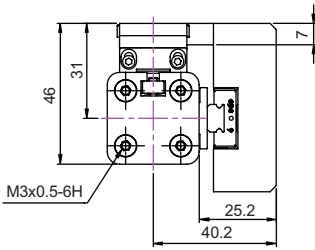
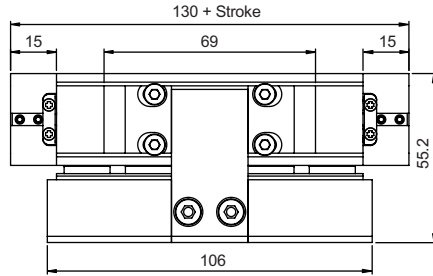

RLO Standard type / Dimensional features

* Free choice of stroke length up to 6000mm.

● $\phi 25$

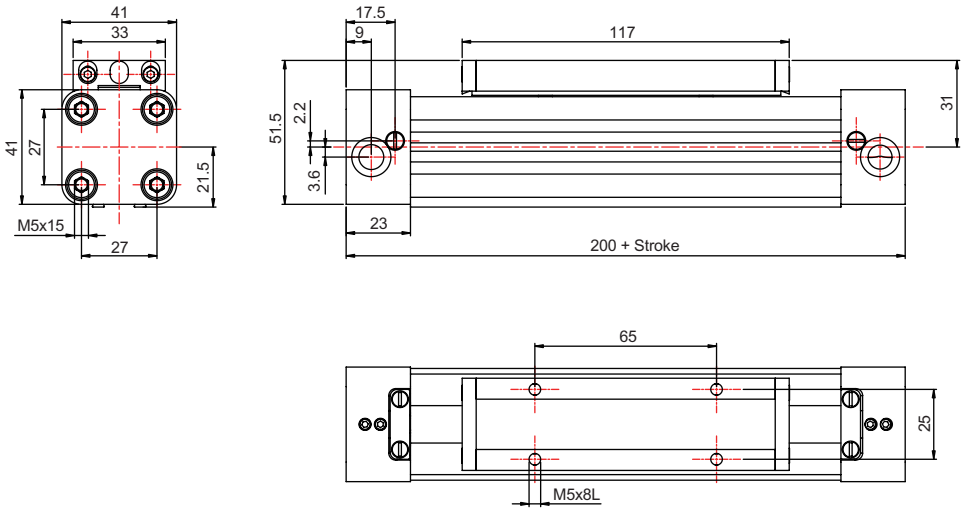

● Stroke

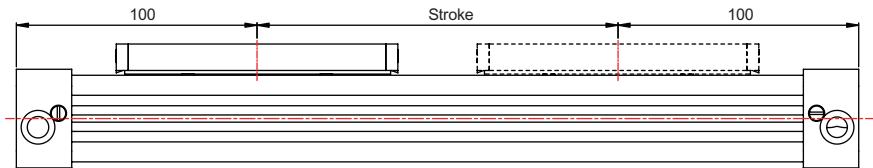

RLO-G Standard type with linear guide/ Dimensional features

* Free choice of stroke length up to 6000mm.

● $\phi 25$

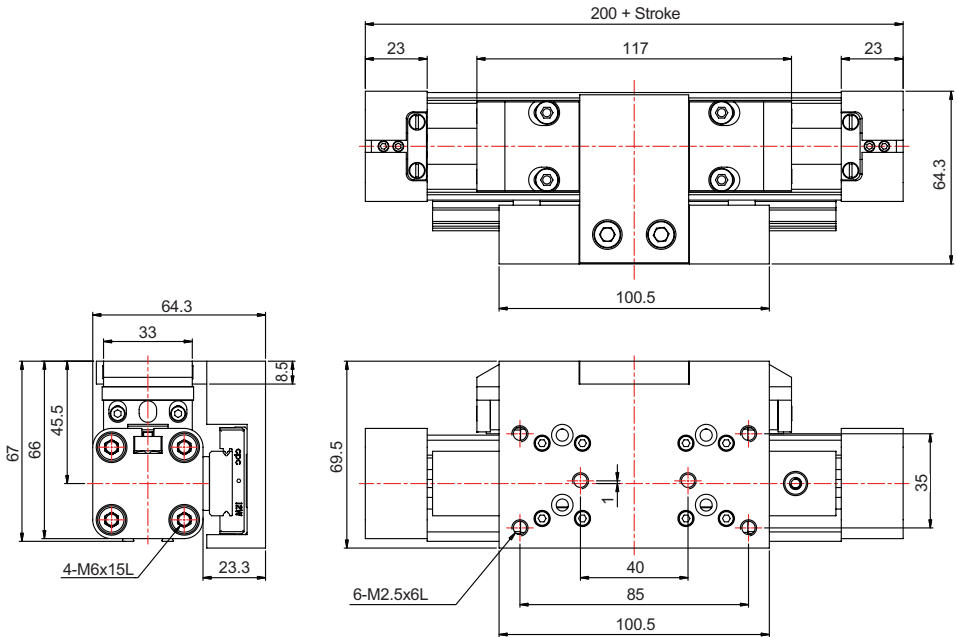

RLO Standard type / Dimensional features

* Free choice of stroke length up to 6000mm.

● $\phi 32$

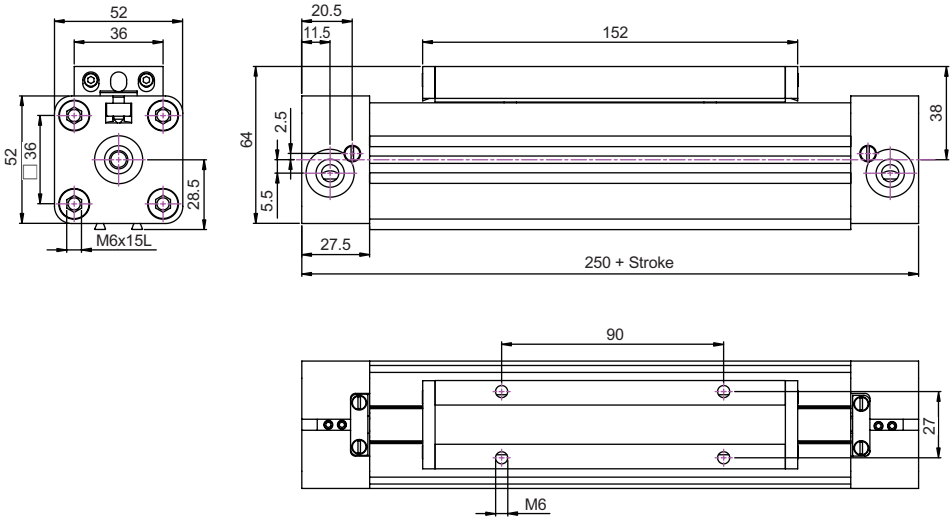

● Stroke

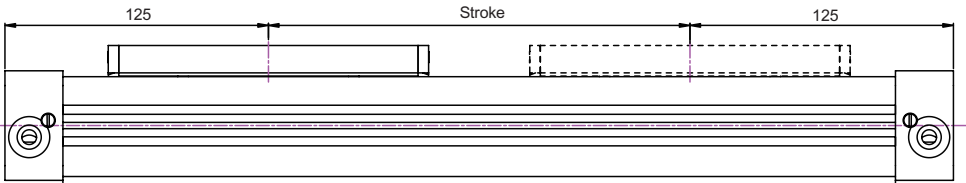

RLO-G Standard type with linear guide/ Dimensional features

* Free choice of stroke length up to 6000mm.

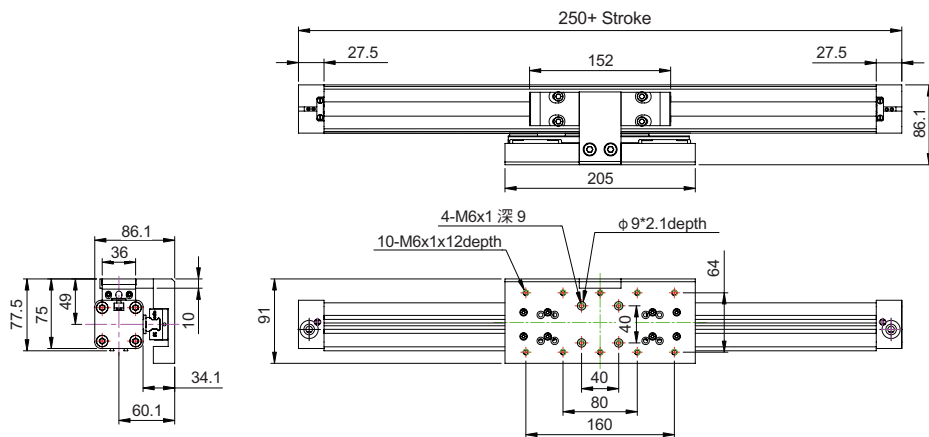
● $\phi 32$ 

RLF Standard type / Dimensional features

* Free choice of stroke length up to 6000mm.

● $\phi 25$

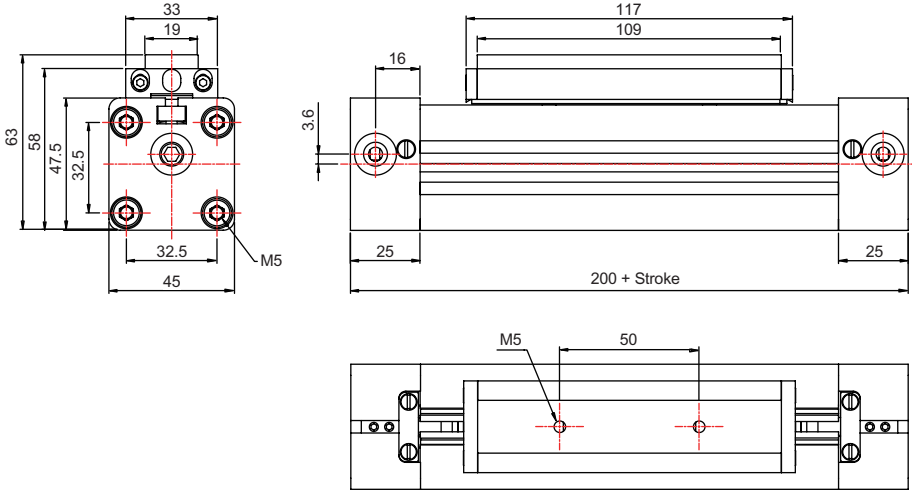

● Stroke

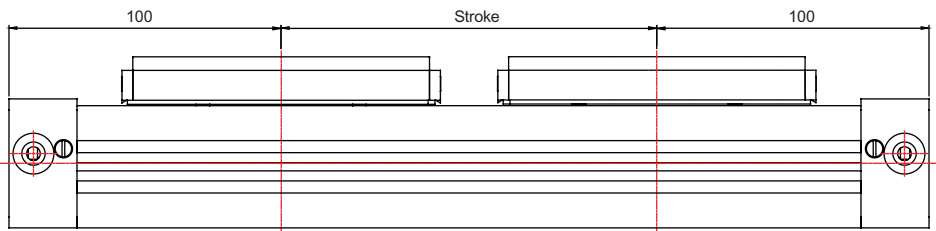

RLF-G Standard type with linear guide/ Dimensional features

* Free choice of stroke length up to 6000mm.

● $\phi 25$

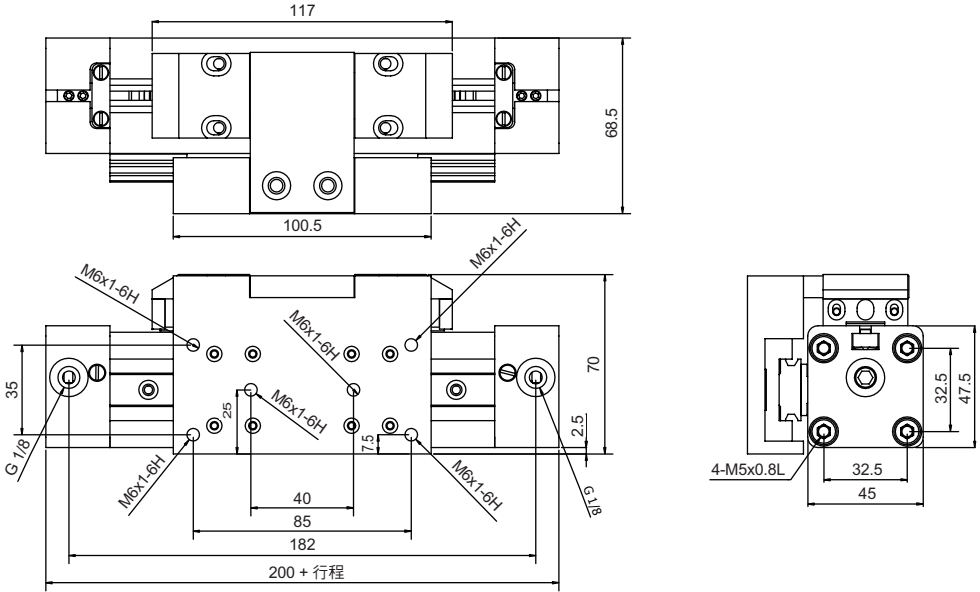

● Stroke

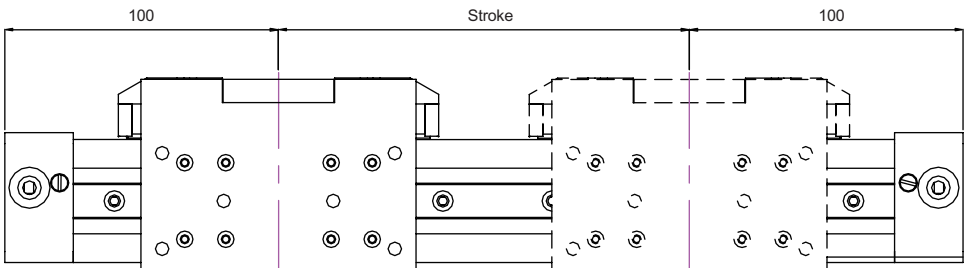

RLF Standard type / Dimensional features

* Free choice of stroke length up to 6000mm.

- $\phi 32$

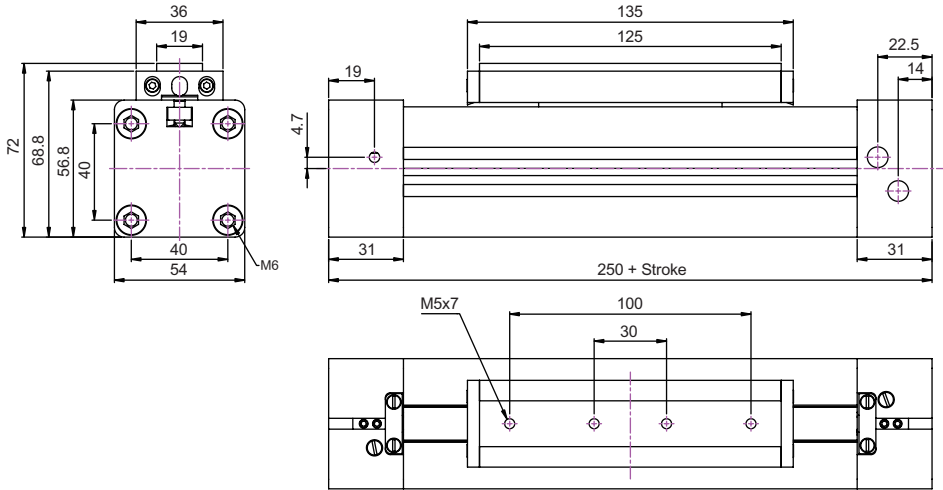

- Stroke

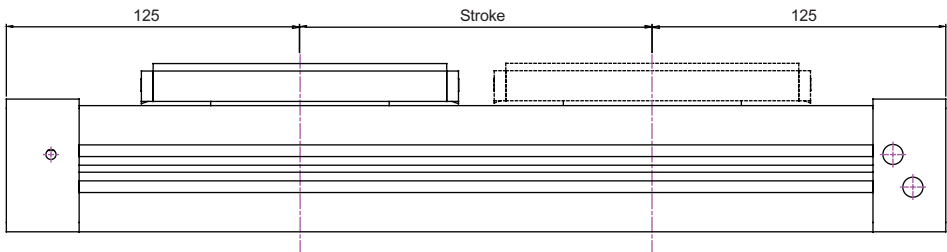

Linear Drive Accessories Clevis Mounting $\phi 16 \sim 63$

When external guides are used, parallelism deviations can lead to mechanical strain on the piston. This can be avoided by the use of a clevis mounting. In the drive direction, the mounting has very little play. Freedom of movement is provided as follows :

- Tilting in direction of movement
- Vertical compensation
- Tilting sideways
- Horizontal compensation

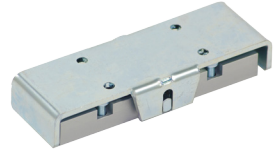

A stainless steel version is also available.

RLO-U Standard type with Clevis mounting/ Dimensional features * Free choice of stroke length up to 6000mm.

● $\phi 25$

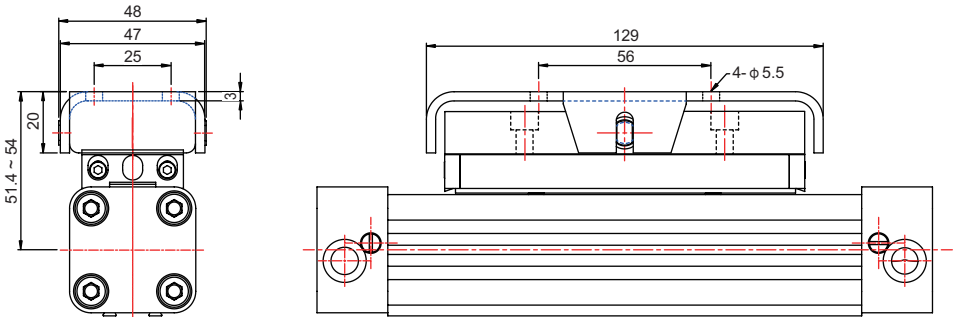

RLO-U Standard type with Clevis mounting/ Dimensional features * Free choice of stroke length up to 6000mm.

● $\phi 32$

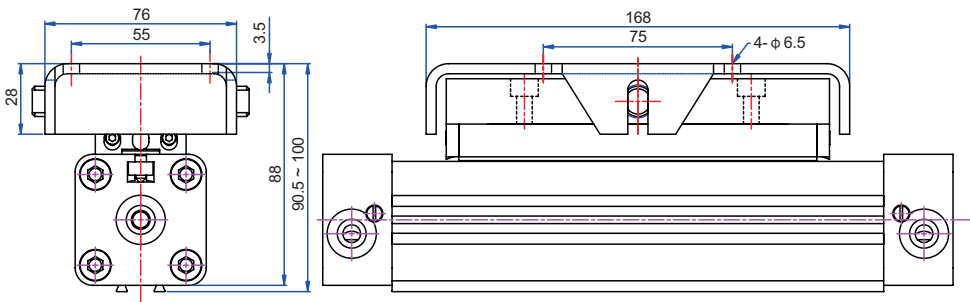

Linear Drive Accessories End Cap Mountings $\phi 16 \sim 63$



On the end-face of each end cap there are four threaded holes for mounting the actuator. The hole layout is square, so that the mounting can be fitted to the bottom, top or either side, regardless of the position chosen for the air connection.

Material :
 RL-O $\phi 16 \sim \phi 32$ Series
 Galvanised steel.
 RL-O $\phi 40 \sim \phi 63$ Series
 Anodized aluminium

The mountings are supplied in pairs.

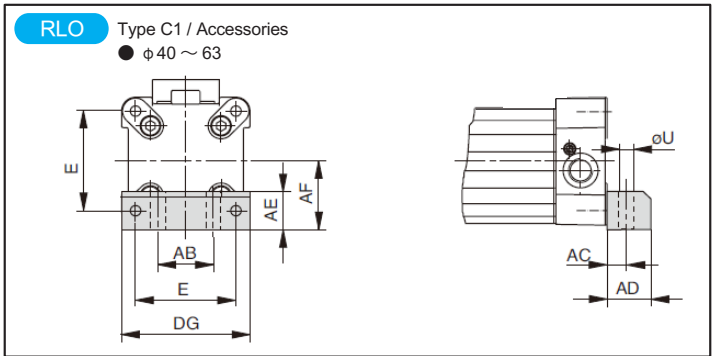
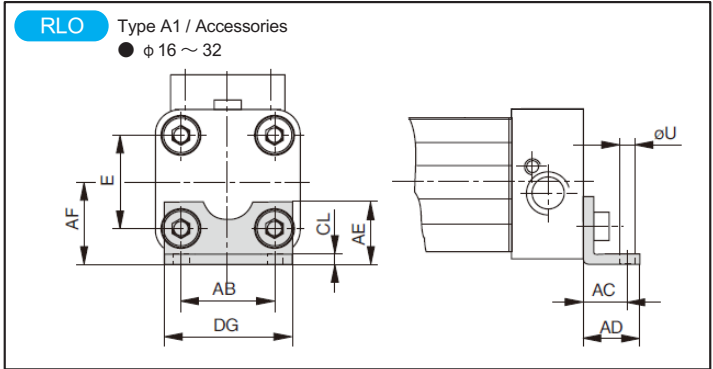

Dimensional Table

Mark Bore	E	ϕU	AB	AC	AD	AE	AF	CL	DG	Order No.	
										Type A1	Type C1
$\phi 16$	18	3.6	18	10	14	12.5	15	1.6	26	20408	—
$\phi 25$	27	5.8	27	16	22	18	22	2.5	39	2010	—
$\phi 32$	36	6.6	36	18	26	20	30	3	50	3010	—
$\phi 40$	54	9	30	12.5	24	24	38	—	68	—	4010
$\phi 50$	70	9	40	12.5	24	30	48	—	86	—	5010
$\phi 63$	78	11	48	15	30	40	57	—	104	—	6010