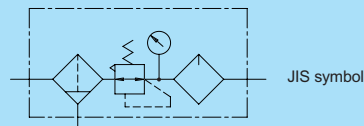

## F.R.L. COMBINATION UNIT

**DSKL**

### Specifications

Type	DSKL-06	DSKL-08
Port size	Rc (PT) 1 / 8	Rc (PT) 1 / 4
Min. flow for oil drip	15 Nl/min	
The range of pressure	0.5 ~ 8 kgf/cm <sup>2</sup>	
Proof pressure	9.8 kgf/cm <sup>2</sup>	
The range of temperature	0 ~ +60 °C (No freezing)	
Filter element	25 μm	
Filter capacity	18 c.c.	38 c.c.
Oil capacity	40 c.c.	60 c.c.

### How to order

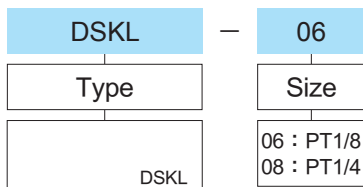

### Flow characteristics

#### ● DSKL-06

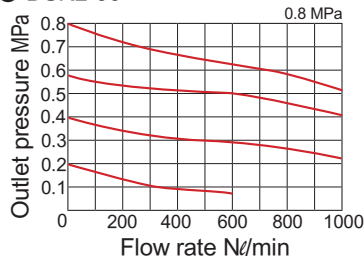

#### ● DSKL-08

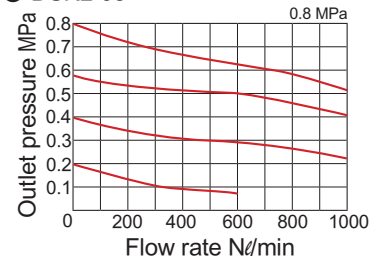

### DSKL

### Dimensional features

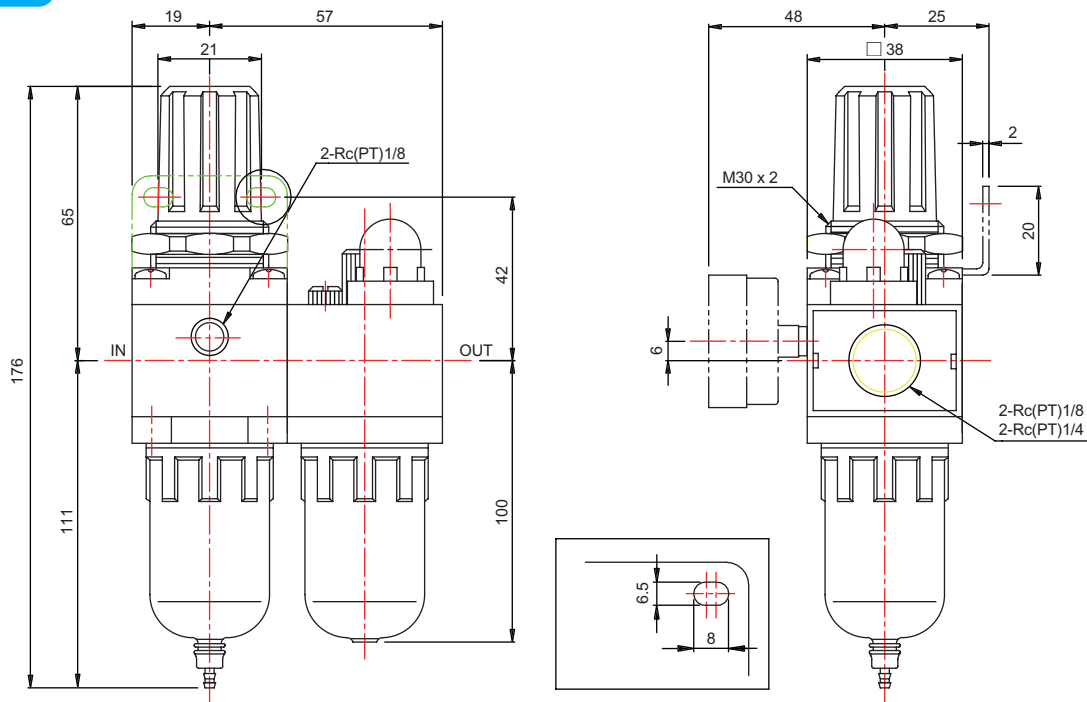

Note : with auto drain