

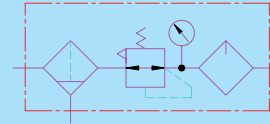

F.R.L. COMBINATION UNIT

DMKL



JIS symbol

Specifications

Type	DMKL-15	DMKL-20
Port size	Rc (PT) 1 / 2	Rc (PT) 3 / 4
Min. flow for oil drip	25 Nℓ/min	30 Nℓ/min
The range of pressure	0.5 ~ 9 kgf/cm <sup>2</sup>	
Proof pressure	9.8 kgf/cm <sup>2</sup>	
The range of temperature	0 ~ +60 °C (No freezing)	
Filter element	25 μm	
Filter capacity	80 c.c	
Oil capacity	130 c.c	

How to order

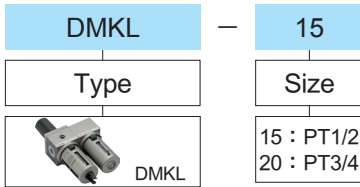

Flow characteristics

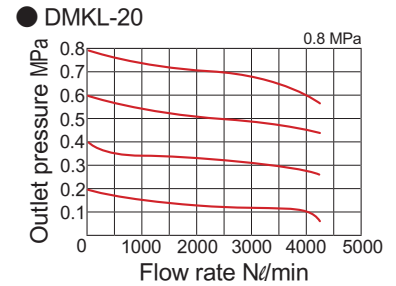
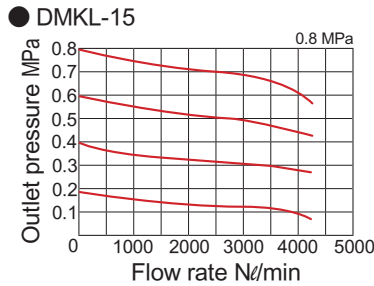

DMKL Dimensional features

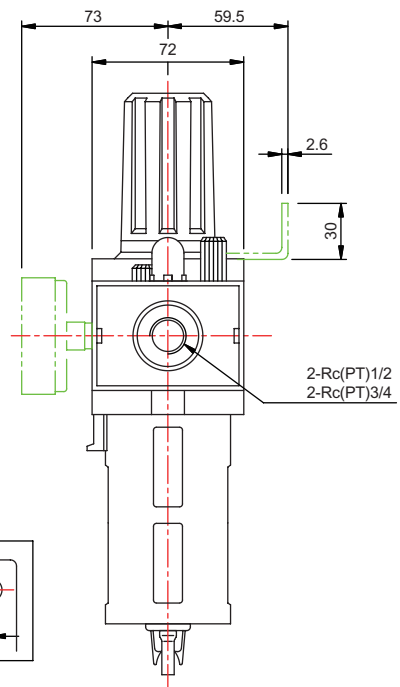
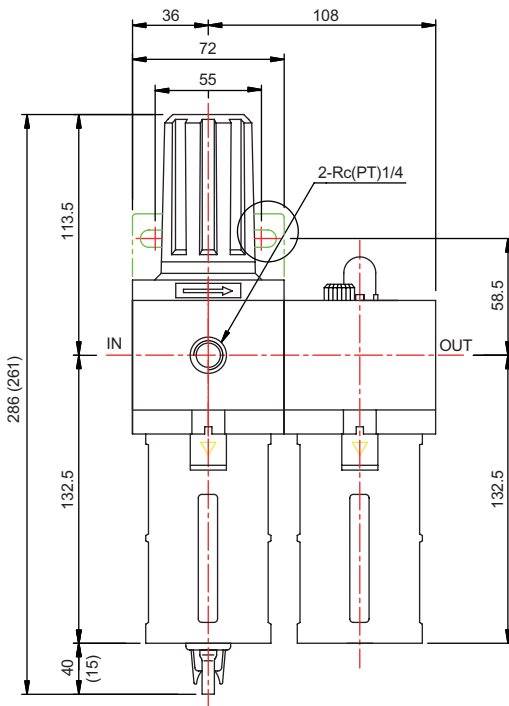

Note : with auto drain