

LUBRICATOR

DAL

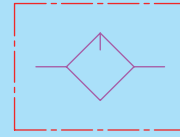

JIS symbol

Specifications

Type	DAL-08	DAL-10	DSAL-15
Port size	Rc (PT) 1 / 4	Rc (PT) 3 / 8	Rc (PT) 1 / 2
Min. flow for oil drip	25 Nℓ/min	30 Nℓ/min	30 Nℓ/min
The range of pressure	0.5 ~ 10.2 kgf/cm <sup>2</sup>		
Proof pressure	16.3 kgf/cm <sup>2</sup>		
The range of temperature	0 ~ +60 °C (No freezing)		
Filter capacity	100 c.c		

How to order

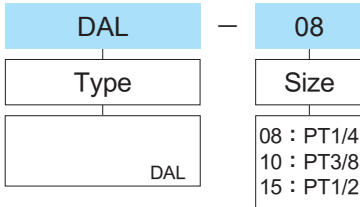

Flow characteristics

● DSAL-06

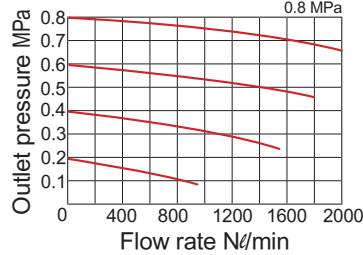

● DSAL-08

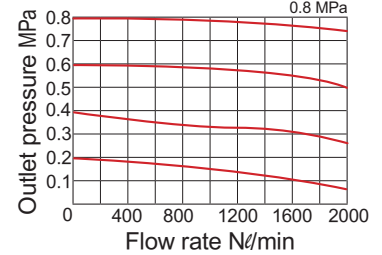

DAL Dimensional features

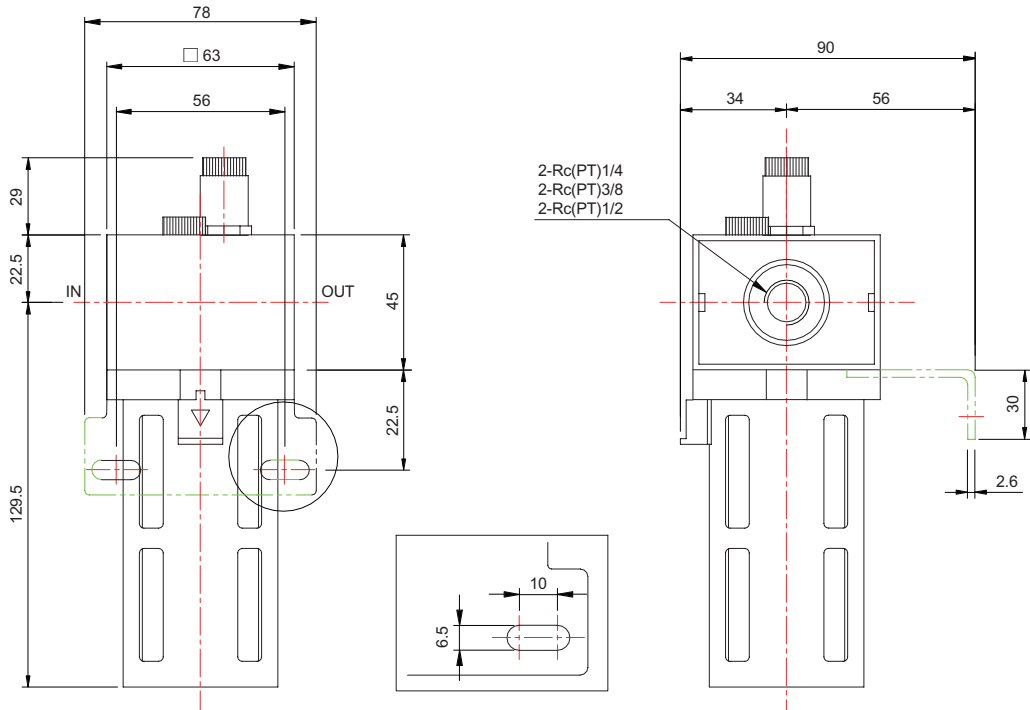

Note : with auto drain